



Procedure to Breakdown Cybex 350

Tools:

- 3/16" allen
- 1/4" allen
- 3/32" allen
- 1/2" box wrench
- 9/16" box wrench
- 7/16" box wrench
- Phillips head screw driver
- Flat head screw driver
- Wire cutters
- Long nose pliers
- Pliers
- 1/2" socket
- 9/16" socket
- 7/16" socket
- Socket extension
- Power Screw Drive with phillips and flat head attachments
- 5 Large sealing plastic bags with labels (seat bolts, plate screws, frame bolts, wheel bag)
- 2"x4"x4 foot piece of wood
- Large box (23"x23"x13") for seat back cushions and bolt box)
- Small box to hold bolt bags
- Small box for calibration weights
- Black marker
- Packing tape
- Heavy Duty Plastic wrap

See Diagram on last page for parts identification.

Unplug Machine from the Wall

Seat backs

1. Separate the seat belt at the adjustment clamp.
2. Remove the bottom seat cushions (2) with a 7/16" wrench. There are four bolts, two in front and two in the back of each cushion. Place pads in large box.
3. Remove the seat back pads (J, I, H (3 pads on each side)) with Phillips head screwdriver. Place screws (total of 24) in the seat bolt bag. Place the pads in the large box.
4. Each seat back is raised and lowered via two gas springs. Use 3/16" Allen wrench to remove gas springs. NOTE: Prop 2x4 behind each spring to counter the force of the spring so you do not strip the bolts. Remove the nut, washers, and bolt from the top of each gas shock and place all in the seat bolt bag.
5. Lower the seatback to the reclined position. Each seat back has 2 allen bolt stops on the inside of the seat back frame by the seat cushion. Remove stops with 1/4" allen and place all the bolts and the washers in the seat bolt bag.

- Each seat back has 4 mount screws located below the seatback hinge, on the side of the bottom seat cushion. Use ½" wrench to remove the nuts and jiggle the seat backs until the allen screws fall out. Place the allen bolts, nuts, and washers (total of 8 sets) in the seatbolt bag.
- Remove the seatback frames from the machine. Tape together.

Remove cable from dynamometer

- Remove the eight white phillips head screws (2 on each surface, top, front, back, and bottom) holding the dynamometer cover on. Remove the dynamometer cover.
- Use 3/32 allen or screw driver to remove green ground wire and white mount holding the cable to the dynamometer (if there is one).
- Disconnect cables (motor, position, and torque).
- Slide cable out of the dynamometer cover.
- Reinstall the cover and the eight screws.

Remove the dynamometer

NOTE: INSIDE THE PEDESTAL IS A GAS SHOCK. WHEN YOU LIFT OFF THE DYNAMOMETER YOU MUST LIFT IT STRAIGHT UP UNTIL THE GAS SHOCK IS CLEARED.

- Loosen pedestal mount clamp and raise dynamometer to the top
- Pop the four black plastic caps covering the bolts on the pedestal mount clamp. Place in frame bolt bag.
- Remove 4 bolts 9/16" wrench which hold pedestal mount clamp in place. Place bolts, caps, and washers in the frame bolt bag.
- Remove 2 bolts 9/16" wrench from the back of the pedestal mount clamp. Place bolts and washers in the frame bolt bag.
- Tighten the pedestal mount clamp.
- Lift the dynamometer straight off the pedestal until you clear the gas shock. Place on the floor.
- One the top of the gas shock should be a gray metal fitting. You will also find one underneath the bottom of the gas shock. Remove the gas shock and the two metal fittings. Tape the metal fittings to the side of the gas shock (black part of the shock).
- Remove the two bolts 9/16" holding the bottom of the pedestal to the bottom frame of the 340. Place bolts, washers, and nuts in frame bolt bag. Set pedestal on the floor.

Remove monitor and keyboard

- The monitor is located on an arm. Since we do not need the monitor you can cut the monitor wires. Remove the screw from the underside of the monitor tray and remove the monitor. Throw out the monitor.
- Since we do not want the keyboard you can cut the keyboard wire. Remove the four nuts from under the keyboard and remove the keyboard. Throw out the keyboard.
- Slide the two white brackets off the keyboard. Put the washers and nuts back on the white brackets. Put the brackets in the plate screw bag.
- The monitor arm is on a post. Where the arm and post connect are two Phillips head screws. Remove the screws and lift off the arm.

Remove computer

- Confirm unit is unplugged

2. Remove all of the guards/panels from the underside and back of the chairs. There are three in the front (one under each chair and one behind the pedestal mount), and three in the back (one behind each seat and one in the middle).
3. Standing behind the machine, in middle, is the speed selector. Carefully lift the speed selector out. You will have to disconnect cables to remove this unit. **NOTE: DO NOT CUT ANY OF THESE CABLES.**
4. Standing behind the machine, on the right side are power outlets. Remove all the plugs.
5. Standing behind the machine, on left side is the CPU. Disconnect all of the cables running to the CPU. **NOTE: DO NOT CUT ANY OF THESE CABLES.** Remove and throw out the CPU.
6. Remove the cable assemble that runs from the Dynamometer, down between the seats. This cable has a black plastic mess around it where it comes from between the seats and up to dynamometer. Ship cable with the unit.
7. Reinstall the six panels.

Accessory cabinet or rack

The CYBEX many or may not include an accessory cabinet or plastic rack.

1. Remove all of the attachments and place in a box.

UBXT Table (on wheels) (GG)

1. Turn UBXT table on its side.
2. Use $\frac{3}{4}$ " wrench to remove all four wheels.
3. Please wheels in UBXT wheel bag.
4. Turn UBXT to upright position.

Preparing for pick-up.

The following steps are required to ready the CYBEX for pick-up. However, you will be sliding and tipping heavy equipment so be sure you have space and are physically able to do the work. If not please stop until you can get help.

1. If the CYBEX seat assemble will fit through your door you can tip it forward and insert a dolly underneath to transport it. If not - seat assemble is shipped on its back. Confirm you have space. Tip the CYBEX seat assembly 90 degrees so it is on its back. To move it lift one side and insert a dolly.
2. The dynamometer can ship as it is on the pedestal.
3. The seat cushions should be in a box.
4. Tape or band the metal seat backs together.
5. The monitor arm can ship as it is or in a box.
6. All attachments should be in a box(es).
7. Speed selector should be packed in a box.
8. UBXT can ship alone.
9. Place all of the straps, attachments, ROM Stops, gas shock, and lower pedestal mount in a box.
10. Place the calibration weights (2 – 25lbs, 1 – 10lbs, 1- 5lbs, and 2- 2.5lbs) weights in small box and tape shut.
11. Place all of the bolt bags in a box. Place that box in the Large box with the seatback pads.

Attach this form to top Seat Assemble

Dear Driver/Shipping:

Following is a list of the equipment you have:

- 1. Seat Assemble**
- 2. Accessory cart or rack**
- 3. UBXT table with two cushions. Tears (yes/no)**
- 4. Gray metal seatback frames (two taped together)**
- 5. Large box (pads inside)**
- 6. Large box (attachments)**
- 7. Small box (calibration weights 70lbs.)**
- 8. Dynamometer on pedestal**
- 9. Speed Selector**
- 10. Other _____**

If you have any questions or your load does not match this list please call Rob Potash at 781-297-2034 x106.

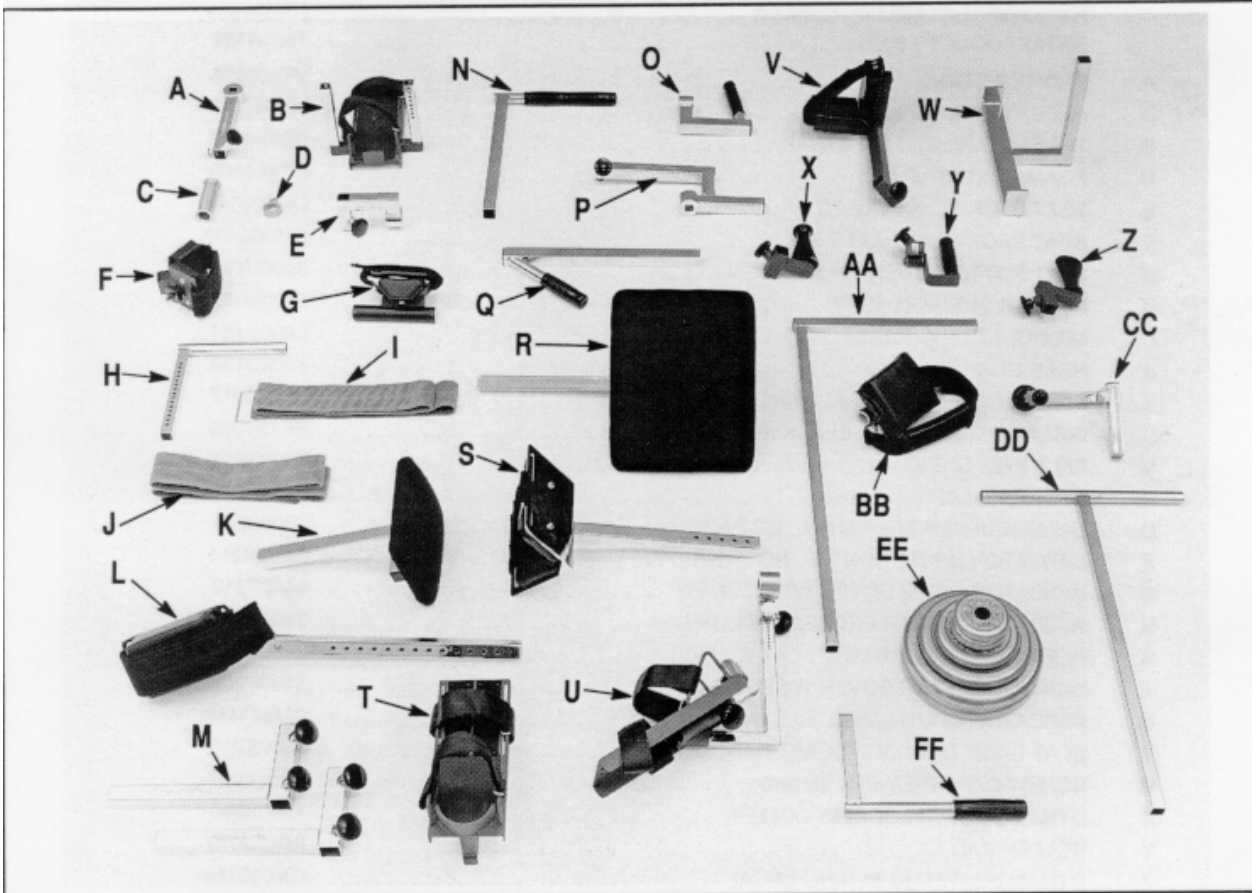
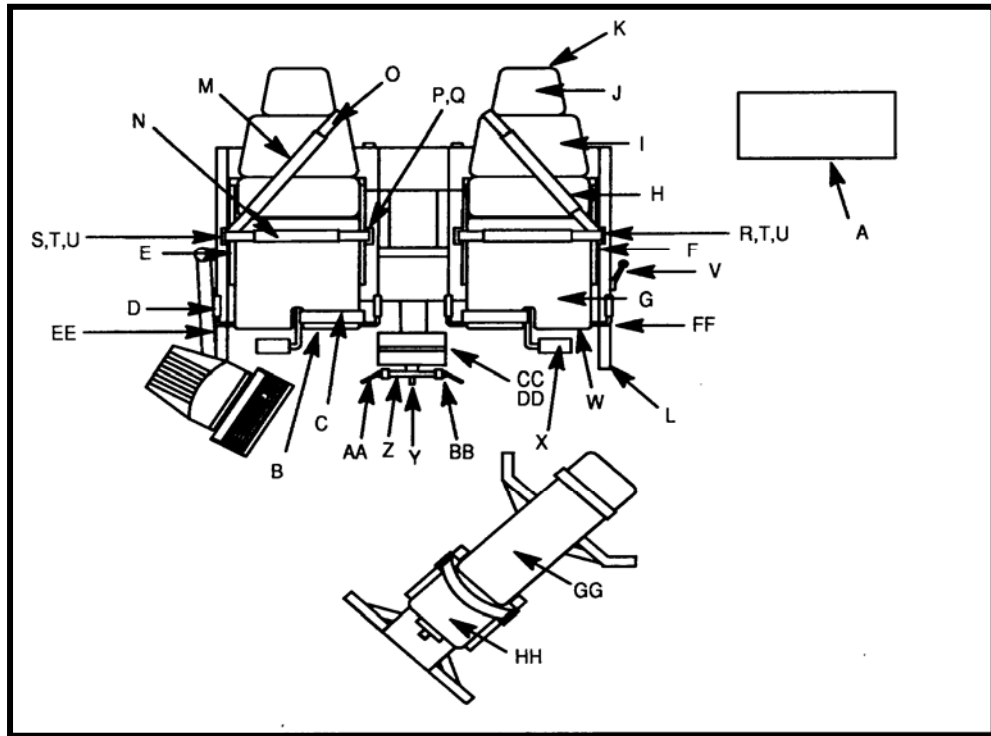

Packing List:

Computer Box:

- Speed Selector
- APS Board w/power cord wrapped on top
- Straps in box on top shelf in box
- Bolt and Wheel bags in box on top shelf

Accessory Box:

- Attachments
- 4 padded mats
- 3 seat frame shields
- Gas Shock with two wedges
- Pedestal

Calibration Weights:

- 70 lbs. In small box

Seat Assemble:

UBXT:

- Remove Wheels

Seat Backs:

- Remove pads and place in box
- Tape together and blanket wrapped

Large Box:

- Seat back pads
- Monitor tray