

Refurbished CYBEX 350 Multi-joint Evaluation and Exercise System



The **CYBEX 350** isokinetic machine is used to rehabilitate and strengthen your patients while providing quantitative measurement of their performance. A CYBEX 350 refurbished by **CSMI** is an affordable solution to your multi-joint evaluation and exercise needs. The CYBEX 350 offers isokinetic and isometric resistance; includes attachments for 18 upper and lower extremity patterns; and can be operated in an 8'x 8' space¹. The CSMI exclusive refurbishment process includes a rebuilt dynamometer, **DELL™** Computer, **HUMAC™/Windows®** Software, updated electronics, paint, straps and pads. Each machine is professionally installed by a CSMI technician, includes an on-site in-service, and is covered by a warranty. Refurbished Extremity Systems by CSMI are the highest quality, most up-to-date, and most affordable systems available!

Each refurbished CYBEX 350 includes:

HUMAC Computer System

- New DELL™ Computer System and Printer
- New HUMAC™/Windows® Software Application
- New HUMAC™ Interface
- New PVI Home Exercise Software

Refurbished Machine Components

- Rebuilt Dynamometer to original factory specification
- New Electronics
- Attachments for 18 Test and Exercise Patterns
- Upper Body Extremity Table (UBXT)
- Calibration Weights
- Paint, Straps and Pads

CSMI Service and Support

- On-site Installation
- On-site Training
- One-year Warranty

Buy Your Refurbished CYBEX With Confidence From CSMI!



Since 1982 CSMI has specialized in the service and support of CYBEX Extremity Systems. We own the designs, manufacturing tools, inventory, and patents for the entire CYBEX Family of isokinetic testing products so you can be confident we'll keep your machine running in top condition.

CSMI
101 Tosca Drive
Stoughton MA, 02072

Phone: 781-297-2034
Fax: 781-297-2039
Email: info@csmisolutions.com

¹Without UBXT

CYBEX 350 Test and Exercise Patterns

SHOULDER

Abduction/Adduction
Horizontal Abduction/Adduction
Extension/Flexion
Internal/External Rotation in Neutral
Internal/External Rotation in 90° of Abduction
Internal/External Rotation in 90° of Flexion

ELBOW

Extension/Flexion

FOREARM WRIST

Pronation/Supination
Radial/Ulnar Deviation
Extension/Flexion

HIP

Abduction/Adduction
Extension/Flexion
Internal/External Rotation

KNEE

Extension/Flexion
Tibia Internal/External Rotation

ANKLE

Plantarflexion/Dorsiflexion (Prone)
Plantarflexion/Dorsiflexion (Supine)
Inversion/Eversion

Other CSMI Products

- PT Website Clinic Website Design Tool
- PVI Home Exercise Software
- SportsWare Injury Tracking Software
- HUMAC Computer System Upgrade for CYBEX Testing Systems
- Service and Support for CYBEX II/II+, 300 Series, Back Series, 6000, and NORM
- New NORM Single Chair Extremity System

CSMI is a sole-source provider of the HUMAC Computer System and exclusive owner of the CYBEX Extremity Family of Products. HUMAC is a registered trademark of CSMI. Copyright © 2003, CSMI. All names, products, and services mentioned are trademarks or registered trademarks of their respective companies.

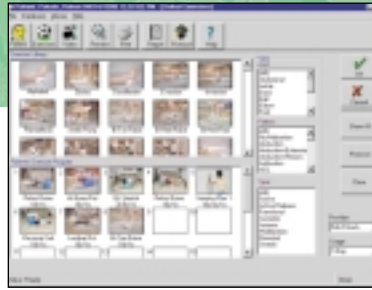

Use the PVI Home Exercise software to create full-page exercise handouts for patients to follow at home.

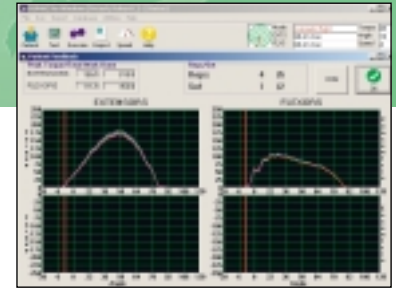

New HUMAC Software provides virtual hands-off operation for more efficient hands-on patient care. Tests can be performed in minutes!

Resistance Modes

Mode	Speeds	Torque
Isokinetic Concentric	12 - 300° per sec	360ft-lbs/488Nm
Isometric		

Power Requirements

Input Voltage: 112-130 VAC (other voltages are available)
Input Frequency: 60Hz (international frequencies available)

Floor Layout: CYBEX 350

Full CYBEX system with seats reclined allowing ankle patterns on positioning table in supine or prone position.

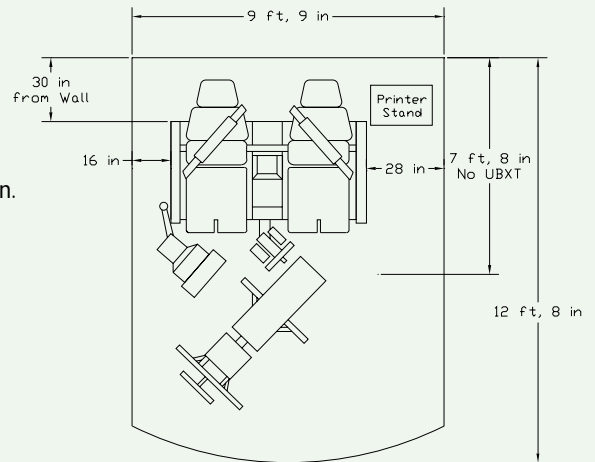

Electrical Specifications: CYBEX 325, 330, 340, 350, TEF, TR, LT

Independent 20 AMP line with an isolated ground, no more than 10 feet from the left rear section of the 300 system. Can be configured for input voltages between 100 and 220 VAC. Shipped configured for 120 VAC. Recommended electrical receptacles are: Eagle P/N IG8410RN and Bryant P/N 8410IG (Hospital Grade).

